



Deutsches
Institut
für
Bautechnik

DIBt

ACO Stormbrixx SD and HD

Installation, maintenance and inspection



Application overview – Find the appropriate Stormbrixx construction

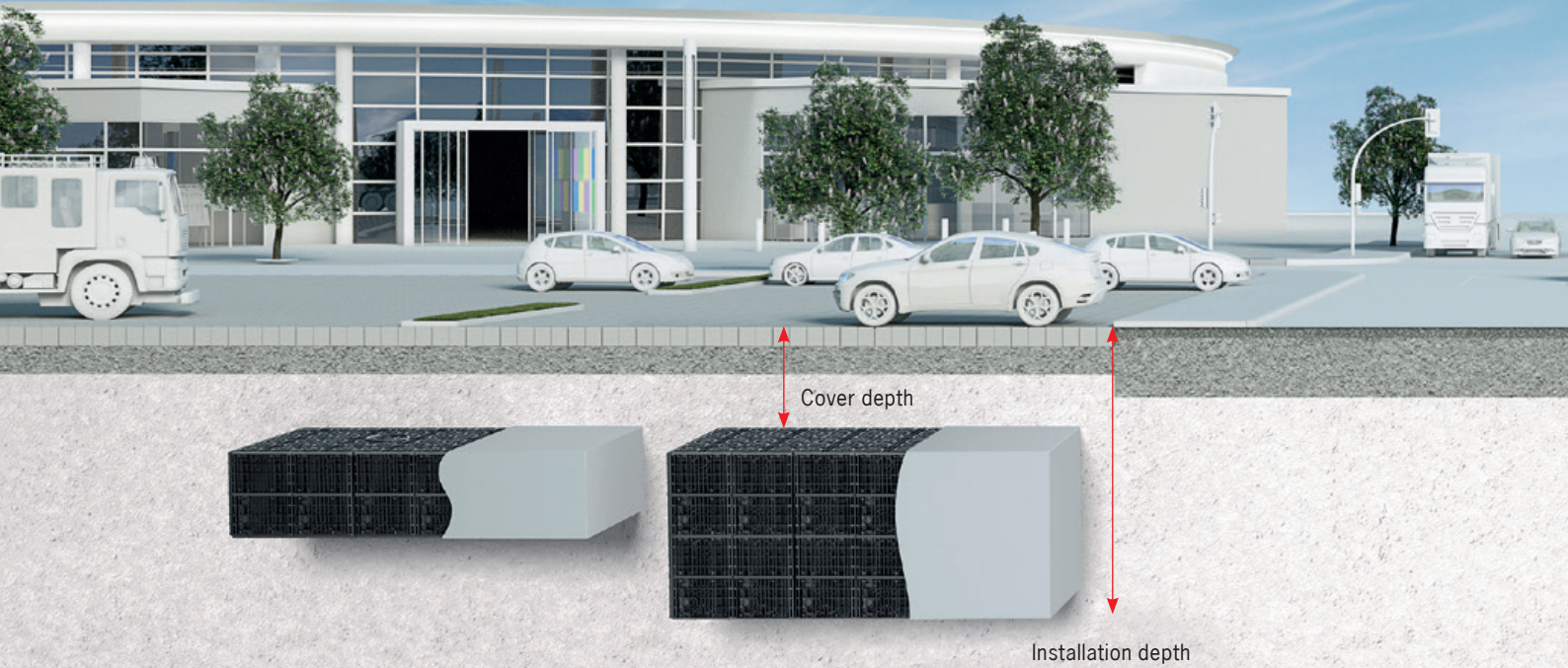

NEW Stormbrixx SD Suitable for car traffic and emergency services

Application category

frost-free installation depth,
at least 80 cm deep (DIN 1054),
without groundwater influence:

- Landscaped areas, no vehicles
- Landscaped areas, driven by mowers
- Pedestrian areas, protected by obstacles (bord, bollards) from driving
- Driveways to carparks, crossing of emergency vehicles possible
- Carparks, crossing of emergency vehicles possible
- Access roads for residential property with scheduled crossings by special vehicles (refuse or tank vehicles) as well as operating service vehicles

Layers	Walkable			Trafficable		
	Cover depth		Installation depth maximal [mm]	Cover depth		Installation depth maximal [mm]
	minimal [mm]	maximal [mm]		minimal [mm]	maximal [mm]	
1	800	2000	2914	800*	2000	2914
2	800	2000	3828	800*	2000	3828

*Please consider the required road construction

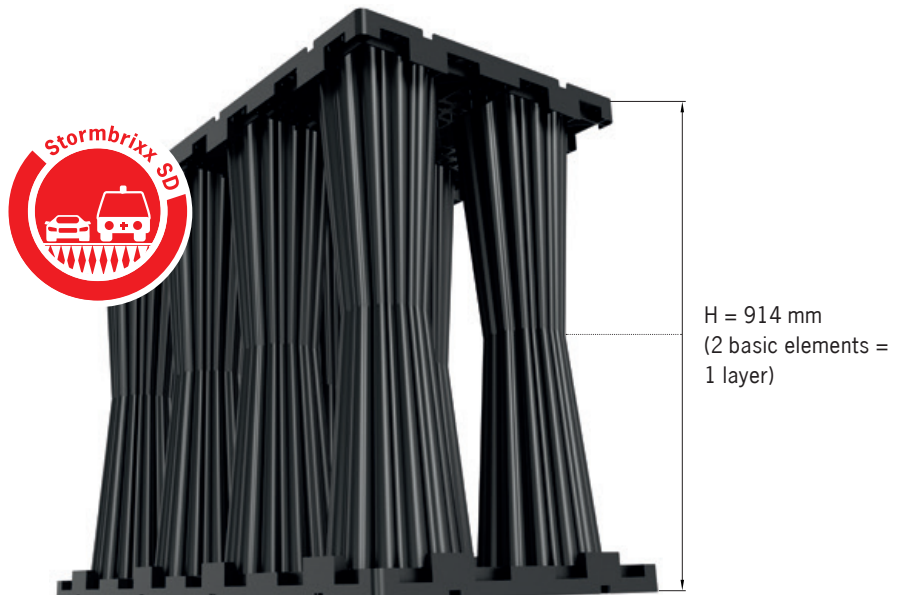

Service

ACO Application engineering advises you.
Please contact them in your country.

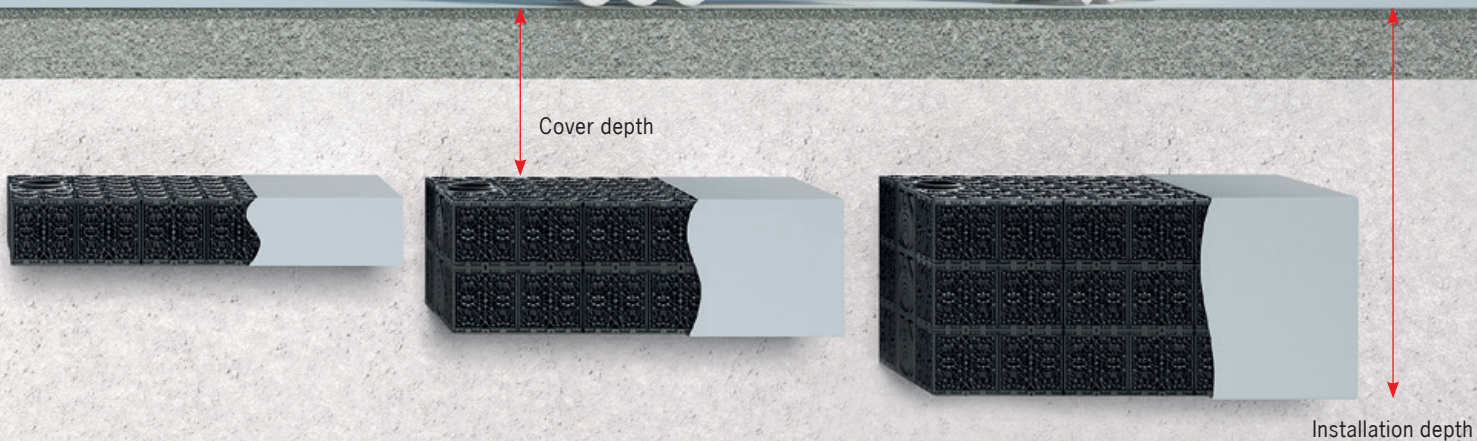
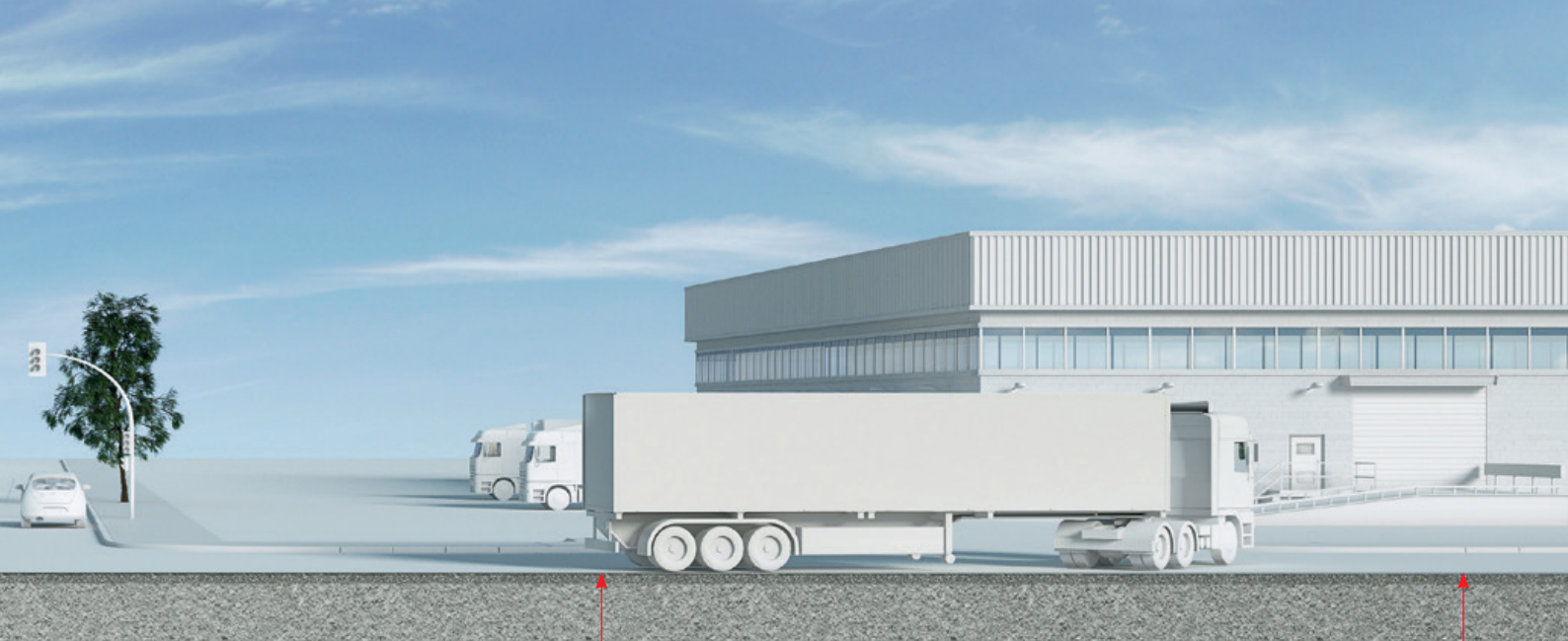

Stormbrixx HD

Suitable for heavy traffic use

Application category

frost-free installation depth,
without groundwater influence:

- Landscaped areas, no vehicles
- Landscaped areas, driven by mowers
- pedestrian areas, protected by obstacles (bord, bollards) from driving
- driveways to carparks, crossing of emergency vehicles possible
- carparks, crossing of emergency vehicles possible
- Access roads for residential property with scheduled crossings by special vehicles (refuse or tank vehicles) as well as operating service vehicles
- Storage areas and secondary facilities of traffic routes which are not constantly used by heavy traffic (mainly stationary traffic, no traffic lane. Connection between storage areas)
- Traffic routes with heavy traffic: only in consultation with ACO Application engineering

Layers	Walkable and trafficable			Trafficable with heavy traffic		
	minimal [mm]	maximal [mm]	Installation depth maximal [mm]	minimal [mm]	maximal [mm]	Installation depth maximal [mm]
1	800*	3400	4010	1000	3400	4010
2	800*	3400	4620	1000	3400	4620
3	800*	3400	5230	1000	3400	5230
4	Please contact ACO Application engineering in your country					

*Please consider the required road construction



H = 610 mm
(2 basic elements = 1 layer)

Installation

Standard soil cover for installation of Stormbrixx SD

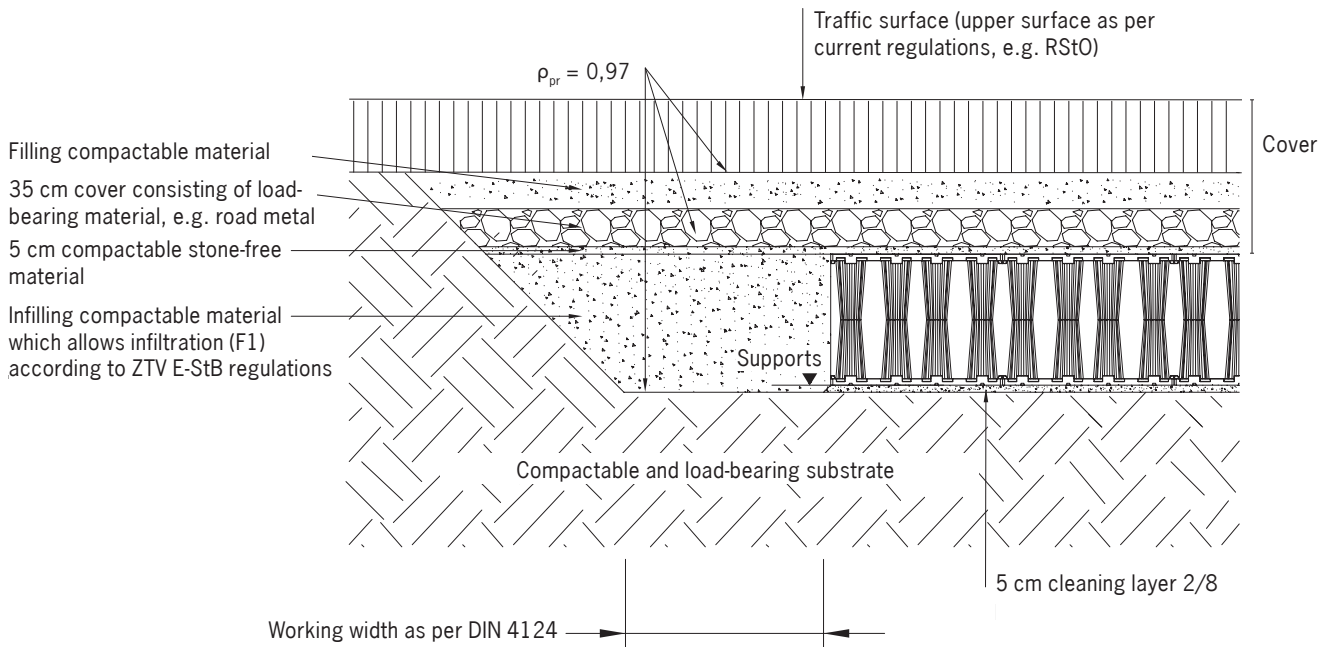

Please note!

The company contracted for the installation is responsible for this being carried out correctly. The basic elements must be inspected for damage before installation. Components can be damaged during transport to or around the construction site at low temperatures (below 5° C). Damaged basic elements, side walls, covers, connectors, pipe adaptors and shaft covers must be not installed!

Installation dimensions Stormbrixx SD

Layers	Walkable			Trafficable		
	minimal ²⁾ [mm] ¹⁾	maximal ³⁾ [mm] ¹⁾	Installation depth maximal [mm] ¹⁾	minimal ²⁾ [mm] ¹⁾	maximal ³⁾ [mm] ¹⁾	Installation depth maximal [mm] ¹⁾
1	800	2000	2914	800*	2000	2914
2	800	2000	3828	800*	2000	3828

*Please consider the required road construction



**Standard soil cover
for installation of Stormbrixx HD**

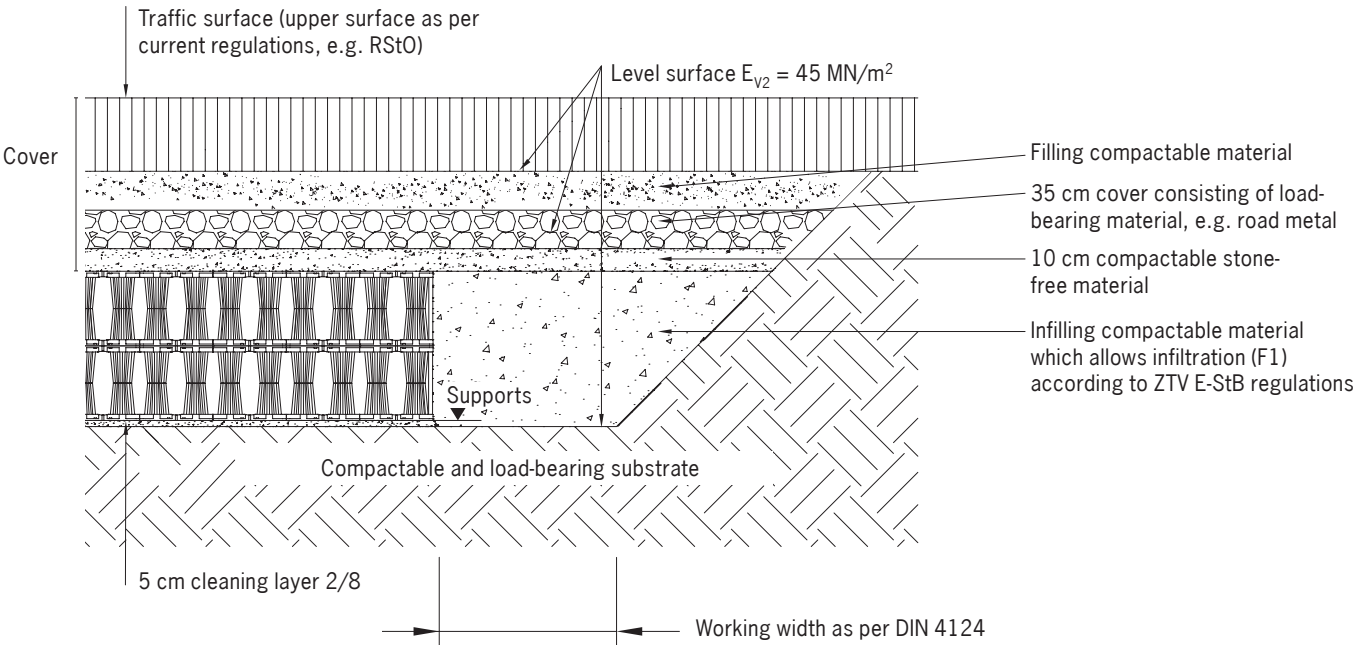

Installation dimensions Stormbrixx HD

Layers	Walkable and trafficable			Trafficable with heavy traffic		
	minimal ²⁾ [mm] ¹⁾	maximal ³⁾ [mm] ¹⁾	Installation depth maximal [mm] ¹⁾	minimal ²⁾ [mm] ¹⁾	maximal ³⁾ [mm] ¹⁾	Installation depth maximal [mm] ¹⁾
1	800*	3400	4010	1000	3400	4010
2	800*	3400	4620	1000	3400	4620
3	800*	3400	5230	1000	3400	5230
4	Please contact ACO Application engineering in your country					

*Please consider the required road construction

To ensure the stability of the system, various requirements and standards must be observed when installing ACO Stormbrixx.

- 1) Ground cover consisting of cover and upper surface as per RStO regulations
- 2) Please allow for local conditions when defining the frost-free installation depth
- 3) Other cover depths for special cases should be agreed with ACO application technology



System configuration

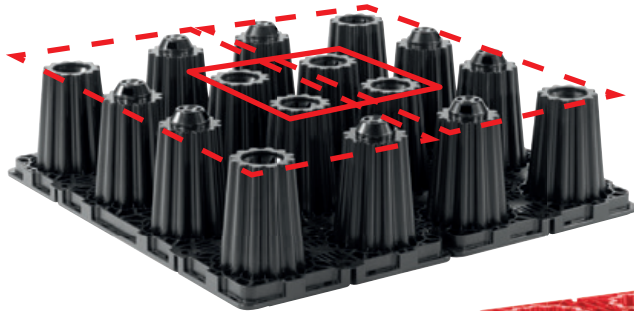

Linking blocks

The basic elements consist of eight columns, of which four are equipped with spigots and four with sockets.

They are easily assembled by plugging together the individual components. The basic elements are assembled with interlocking to optimise the positional safety of the overall system. To achieve this, four push-fit connections must be positioned next to each other.

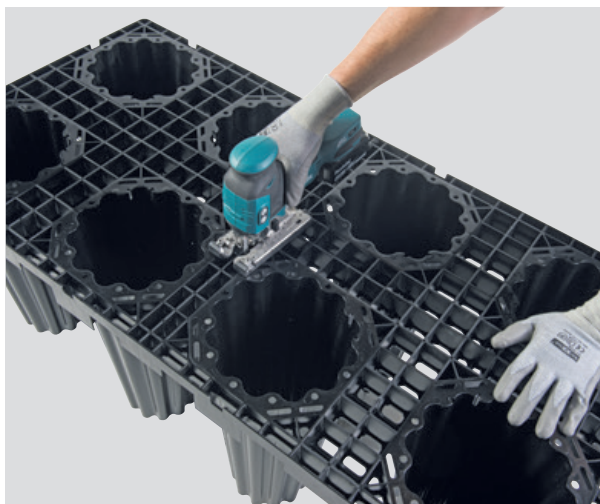

Halve the basic elements

ACO Stormbrixx basic elements can be bisected along their central rib using a handsaw or jigsaw. Each half can be linked to the rest of the system using connectors. The cut surfaces must face into the centre of the tank system.



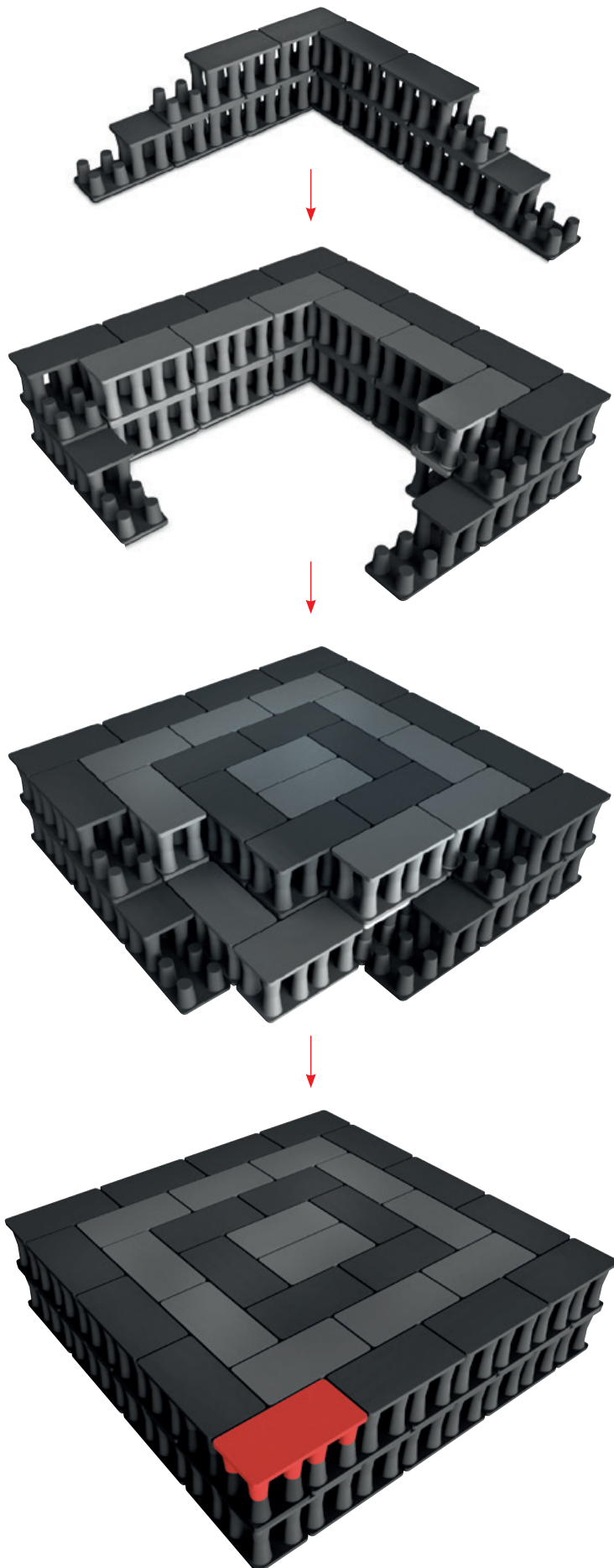

Recommended layout:

Concentric design

This is a series of rings, which become increasingly smaller as they approach the middle of the system.

1. Set out the outlines of the system and level the base of the excavation and lay a levelling layer of sand ($H = 5\text{ cm}$) to form the formation.

2. Lay geotextile (filter nonwoven) and/or waterproof membrane if necessary
3. Set the outer perimeter of the infiltration system with basic elements.

Principle:

Two ACO Stormbrixx basic elements are placed on the ground. A third basic element is turned upside down and is laid on the first two elements in a block bond.

4. If necessary, cut half-basic elements to size
5. Repeat steps for all other layers.
6. Connect together the individual layers with the help of the connectors
7. For large systems (larger than 100 m^3), we recommend starting the installation from a corner, an end or a side. At the same time, begin assembling the inner rings.

If necessary, connect existing rings and layers with the help of connectors.

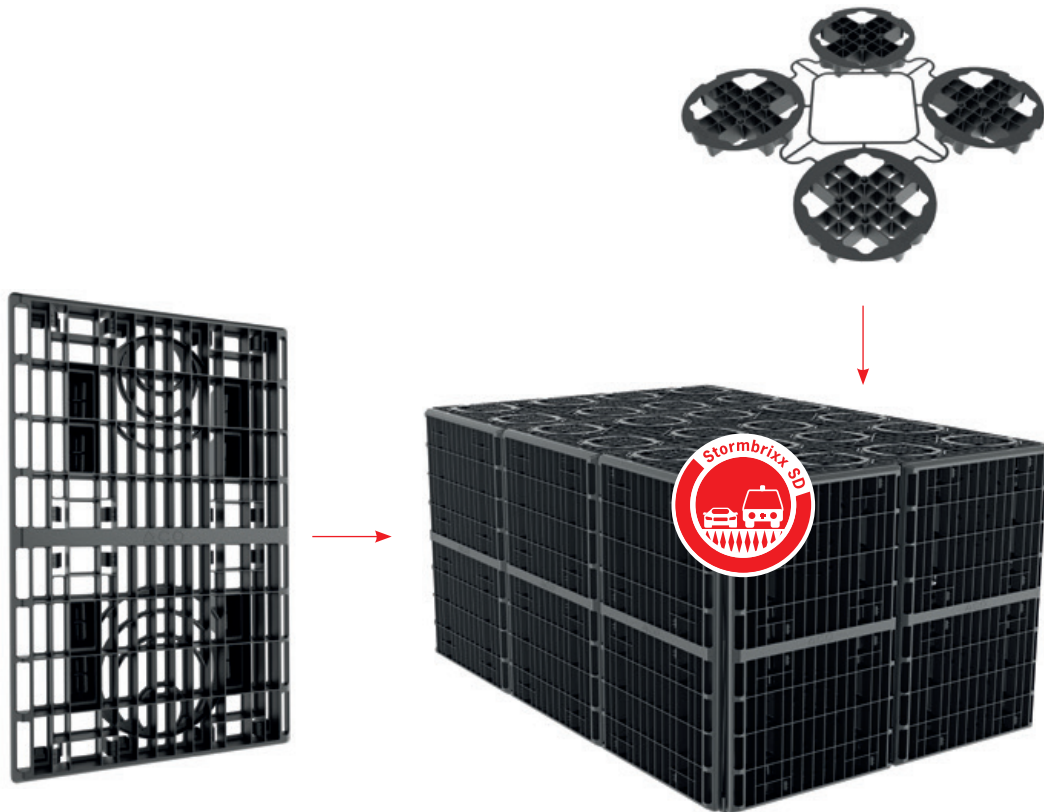

Side panels as the outer boundary



Covers close off the top layer



Side panel and top cover

The side panels are only used at the outsides of the block infiltration system. The covers are only used to close off the openings of the columns in the top layer. If necessary, pipe connections DN/OD 110–315 can be cut out in the places provided (markings).

Different side panels and covers are available for ACO Stormbrixx SD and HD.

Infiltration/attenuation system

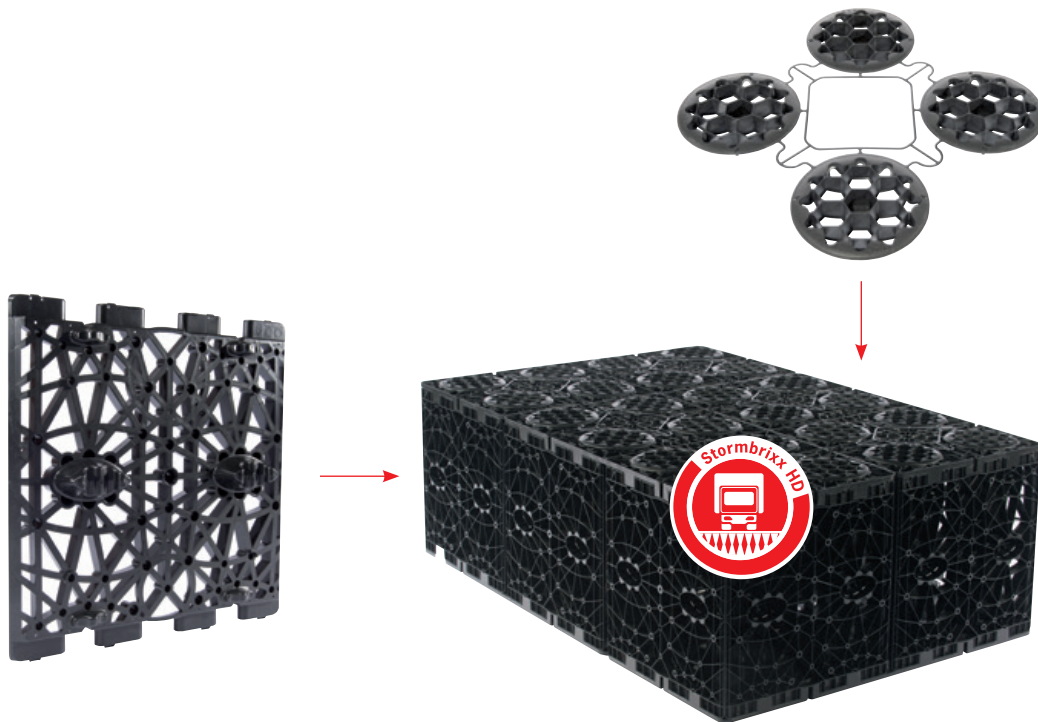

Side panels as a clean system surface for the enveloping geotextile

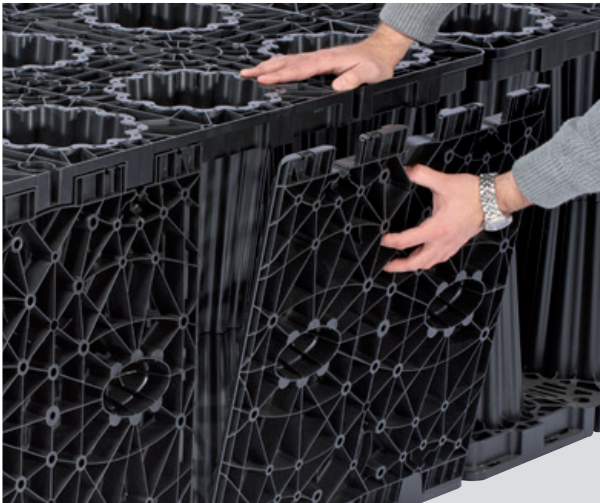

Covers prevent geotextile and soil from penetrating the system



Installing the side panel

Easy assembly: The side panels latch into the basic elements and close off the outer border of the infiltration system. Due to the soil pressure, the geotextile cannot penetrate into the infiltration system.

Installing the top cover

Fast attachment: Four column openings can be closed off in a single step with the help of the ACO Stormbrixx cover. Covers are only mounted on the top layer of the basic elements, before installing the geotextile.

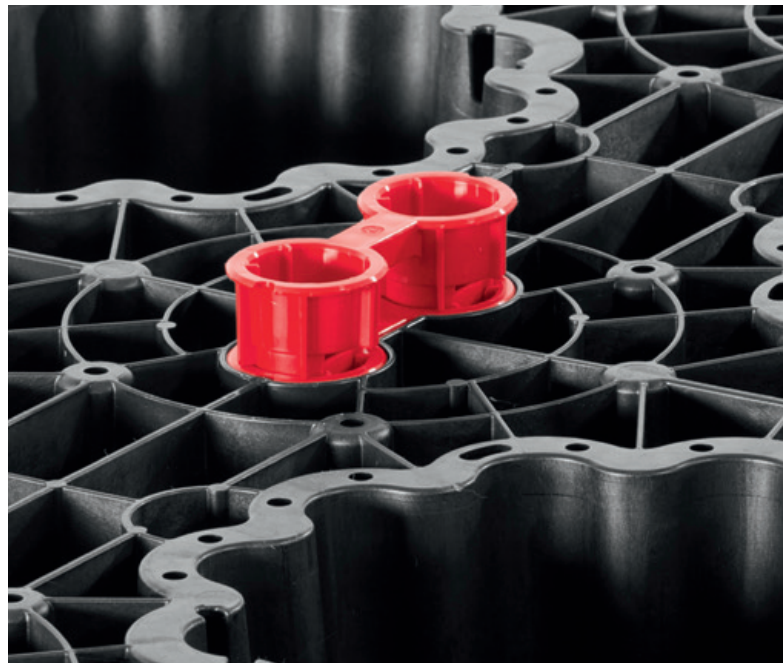
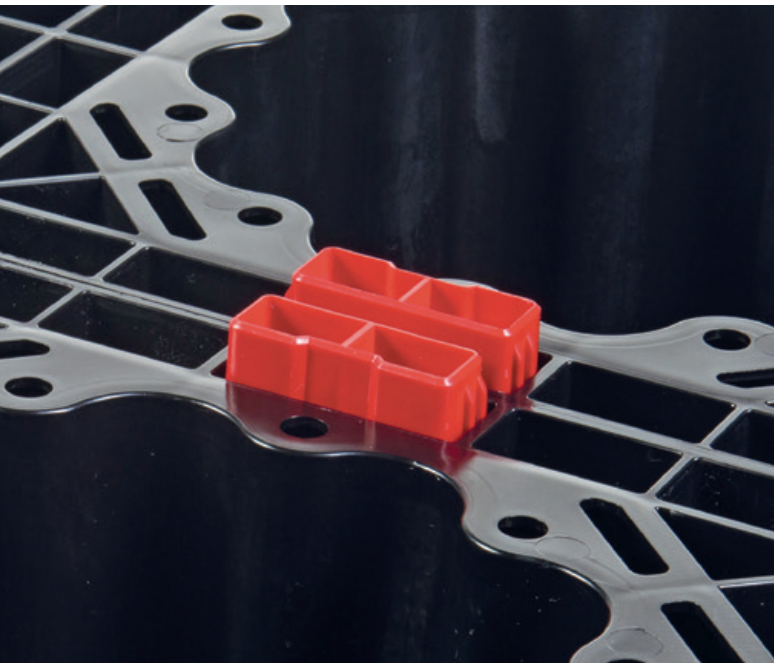
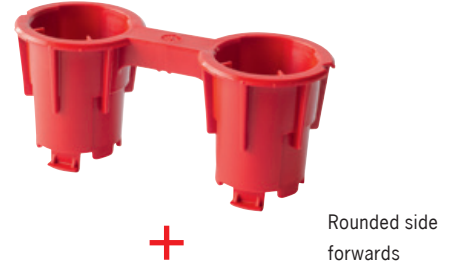
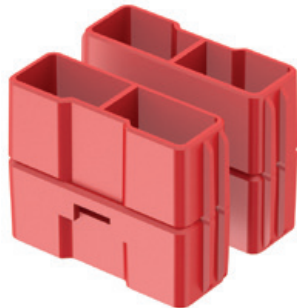
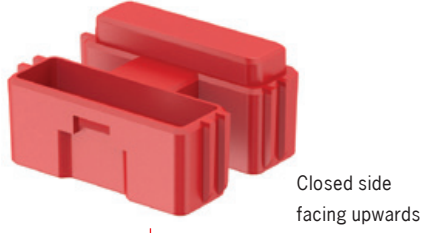
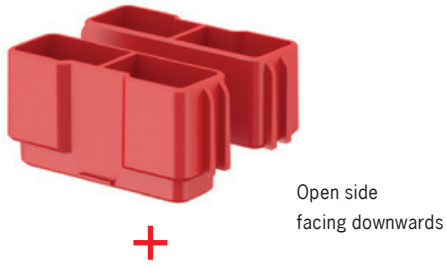

Connectors

When assembling two or three layers of ACO Stormbrixx, the layers are aligned and secured positionally by means of two connectors pushed together. The exact position of the basic elements and connectors within the overall infiltration system is shown in the laying diagram!

The connectors must each be mounted in the middle of the basic element.

Installing one layer

If only one layer of ACO Stormbrixx is installed, unlike other block infiltration systems, **no connectors** are required. Laying the basic elements in the interlocking bond or pattern (see page 32/33) provides additional stability for the overall system.

Installing several layers

Connectors are used if two or more layers of ACO Stormbrixx are installed: Two individual connectors are pushed together to form one and are inserted between the individual layers as positional fixing. This helps to achieve precise alignment of the spigots of several layers.

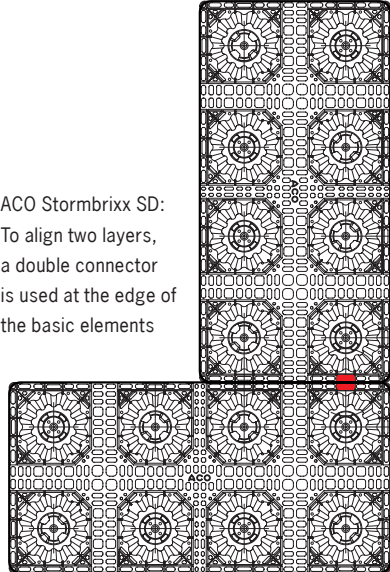

ACO Stormbrixx SD:
Two connectors pushed together secure the alignment of the spigots of two installation layers

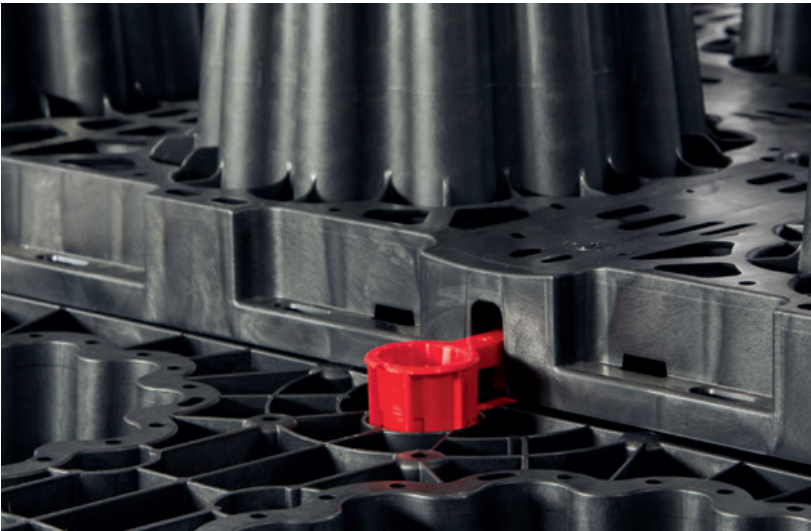
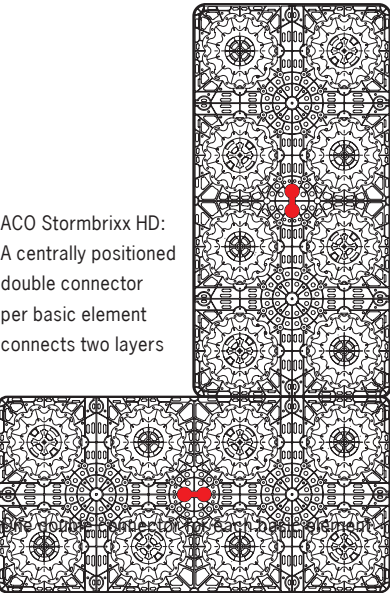

ACO Stormbrixx HD:
Two connectors pushed together secure the alignment of the spigots of two installation layers

Inspection and maintenance access

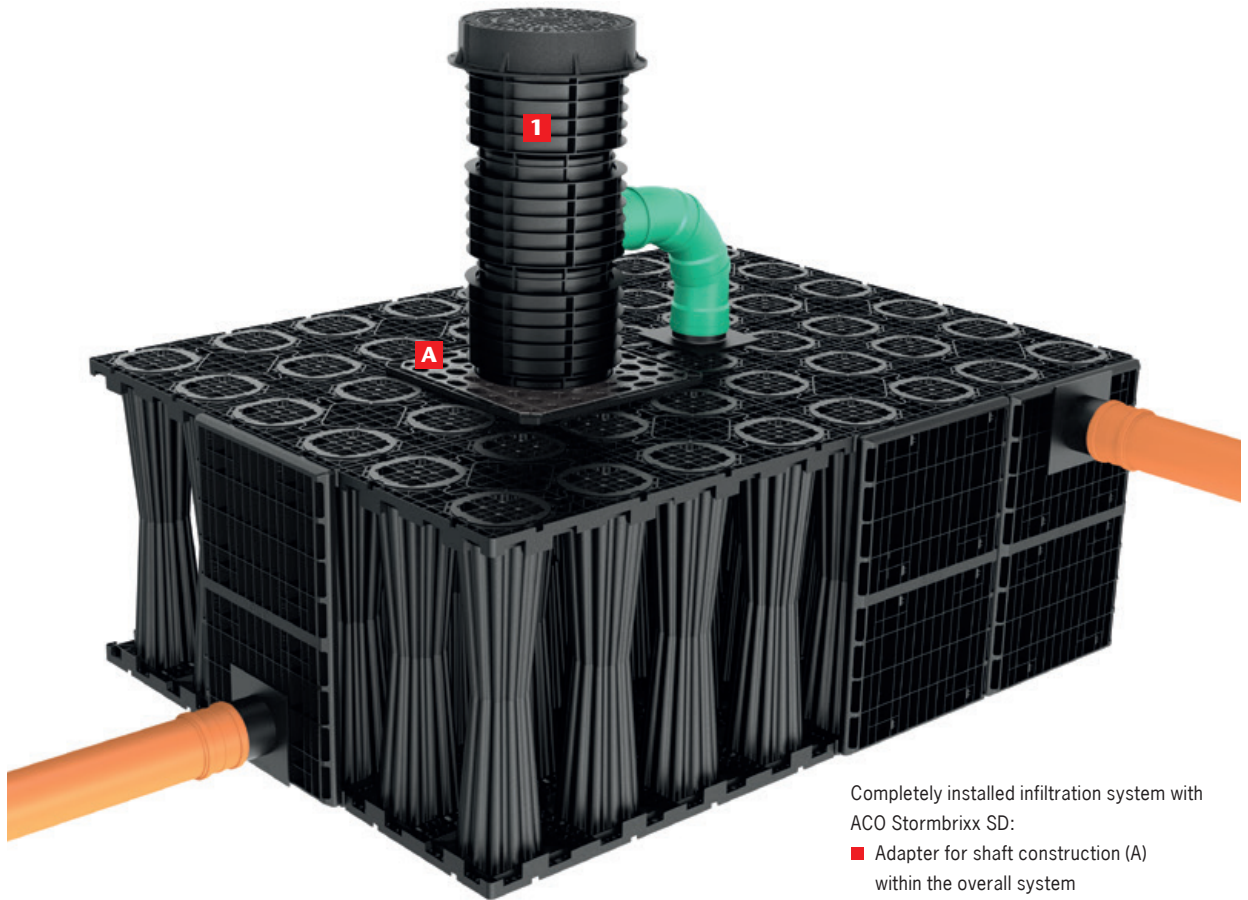

Completely installed infiltration system with ACO Stormbrixx SD:

- Adapter for shaft construction (A) within the overall system
- Upper part (1)

Entrance via access plate

The ACO Stormbrixx Adapter for shaft construction (A) is installed as an inspection access **within the block infiltration system**. An inspection shaft can thus be installed quickly and economically by simply assembling in the required place. The ACO Stormbrixx upper parts (1) are added to the top of the access.

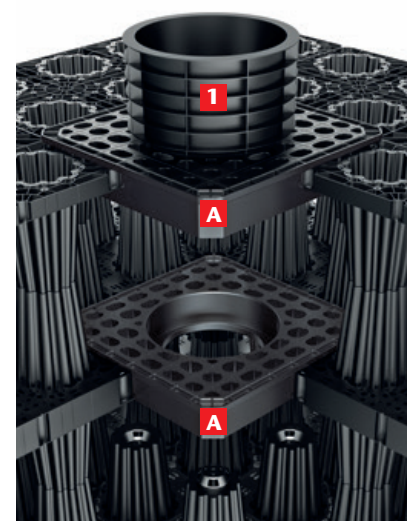
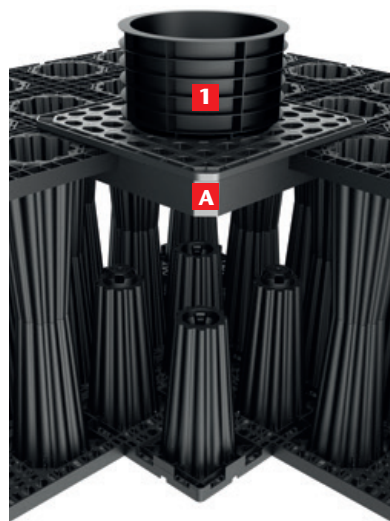
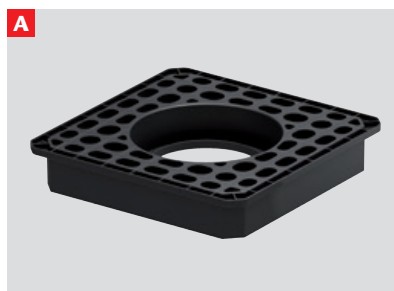

Infiltration system with ACO Stormbrixx SD:
The adapter for shaft construction (A) together with the ACO Stormbrixx upper part (1) is mounted within the overall system for inspection and cleaning of the infiltration system

Infiltration system with ACO Stormbrixx HD:
If accesses are required within the system, the adapter for shaft construction (A) can be used together with the upper part (1) as an alternative to the shaft base or intermediate part (B)

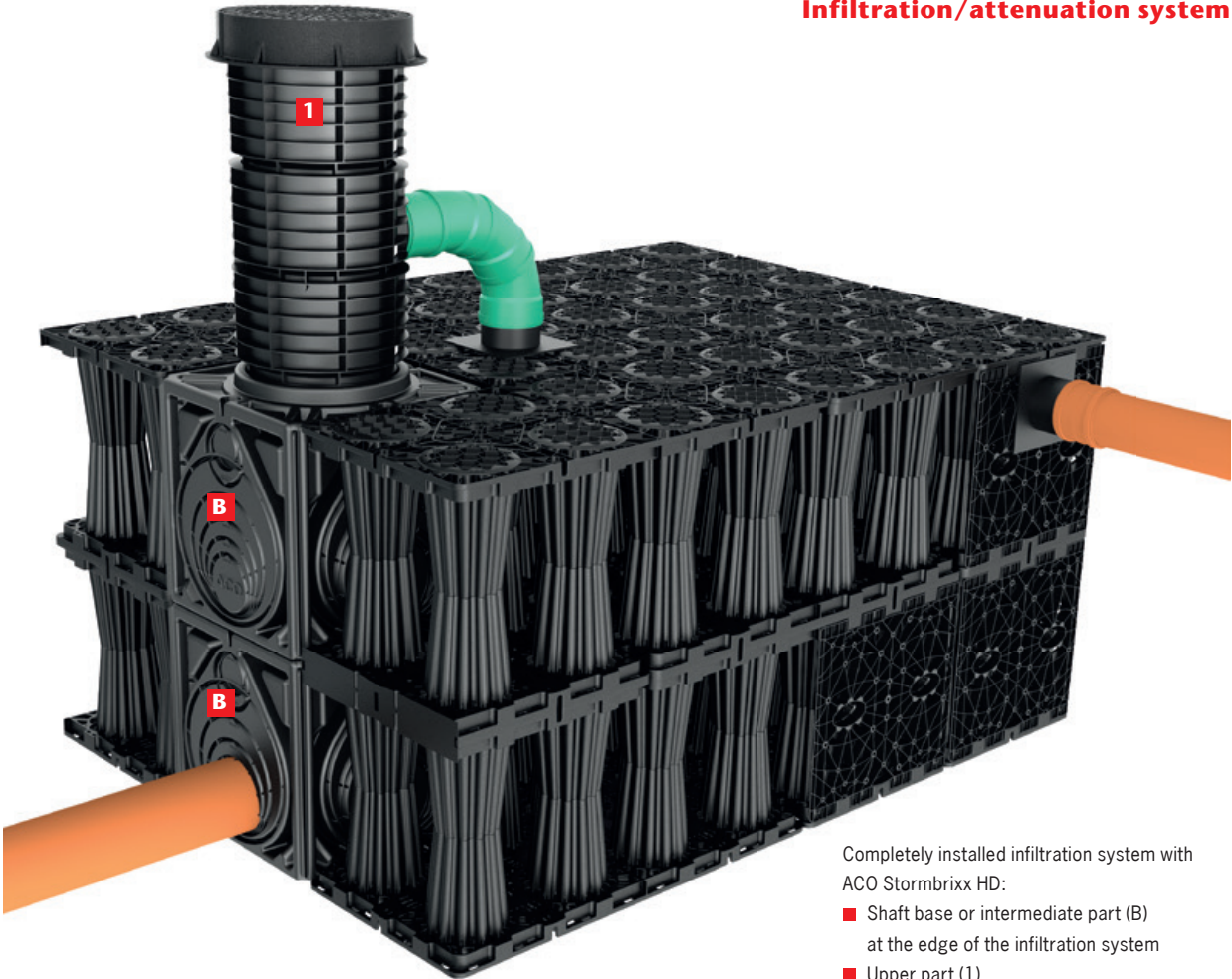

Completely installed infiltration system with ACO Stormbrixx HD:
 ■ Shaft base or intermediate part (B) at the edge of the infiltration system
 ■ Upper part (1)

Entrance via access chamber



For ACO Stormbrixx HD, the shaft base or intermediate part (B) can be integrated not only in the overall block infiltration system but also at the edge of the block infiltration as a connection and inspection shaft. In multi-layer infiltration systems the shaft bases and intermediate parts are simply assembled on top of each other.

Each shaft base and intermediate part can be cut out on site for different pipe size connections according to the in situ requirements (DN/OD 110, 160, 200, 315, 400).
 Tip: It is advisable to make a predrilled hole for the saw blade.
 The top of the shaft is added with ACO Stormbrixx upper parts (1). The height is variable and is adapted to the ground level. A shaft cover rounds off the modular system.

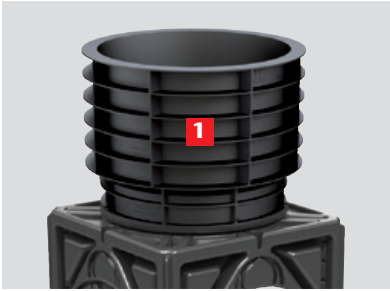

Only in conjunction with Stormbrixx HD!
 The shaft base and intermediate part can be used at the edge of the infiltration system for inspection and cleaning of the infiltration system. A lateral pipe connection DN/OD 400 can be made via this.

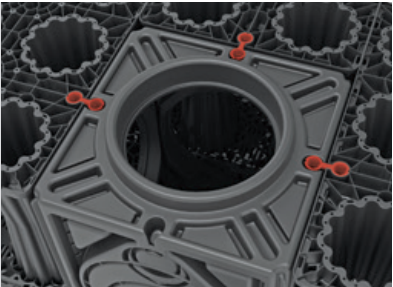

Shaft bases and intermediate parts are connected with individual connectors at the edge of the basic element.
 Do not use connectors on the underside!

Manholes

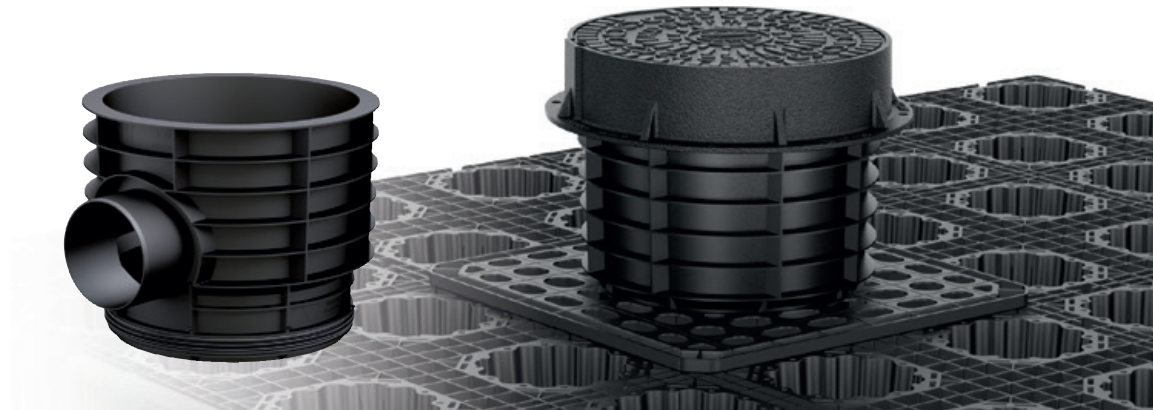

ACO Stormbrixx offers two options for accessing the system with a sewer camera or jetting nozzle or lance for inspection or maintenance of the block infiltration system (see page 60/61). Shaft upper parts enable access to the Stormbrixx system from the surface.

The upper parts with and without sockets can be rotated to match the pipe axis. Their push-fit connection can be adjusted to the longitudinal and transverse gradient on site and can be telescopically

adjusted vertically (+/- 30 mm). They are watertight up to 0.5 bar.

Load separation and vertical alignment of the individual components are ensured by the telescope principle. Any settlement that occurs in the backfill area can be absorbed by the tolerance window in the telescope. The load of the shaft cover is dissipated by the support of the shaft frame in a fresh concrete bed.

Caution!

- Before inserting upper sections, remove protective film from seal and clean it
- Seals must be coated with a suitable lubricant
- Upper section must be inserted to at least the minimum insertion depth!

Insert the upper sections

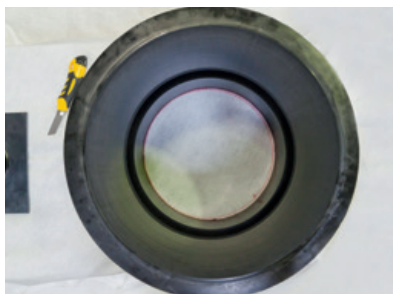

Drawing the inner diameter

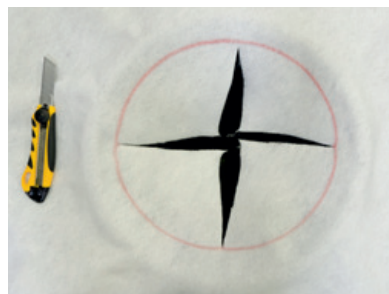

Cutting a cross within the marked circle

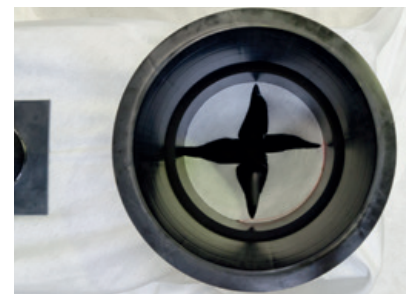

Installing the intermediate section (= sand tight)

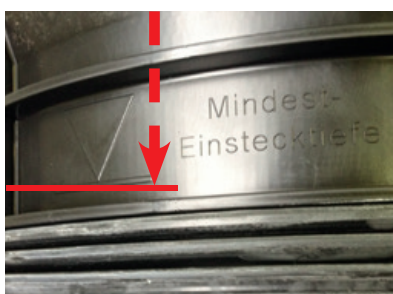

Insert to at least the minimum depth!



The temporary cover/formwork must protect the opening throughout the whole of the construction phase



Creating a ventilation:
A pipe elbow connects the upper part with the nozzle and the pipe connection adapter

Inspection via different access points



At the edge of the box
via the ACO Stormbrixx upper part
(inner diameter = 339 mm)
in connection with the access chamber
(inner diameter = 400 mm)

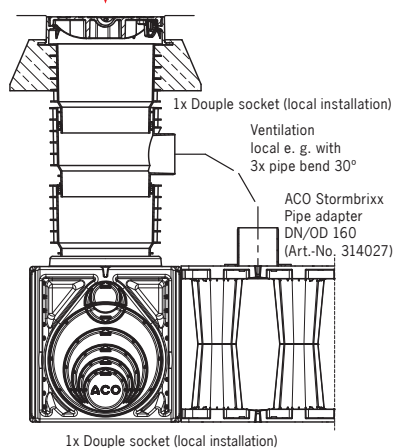

Within the box
via the ACO Stormbrixx upper part
(inner diameter = 339 mm)
in connection with the access plate
(inner diameter = 400 mm)

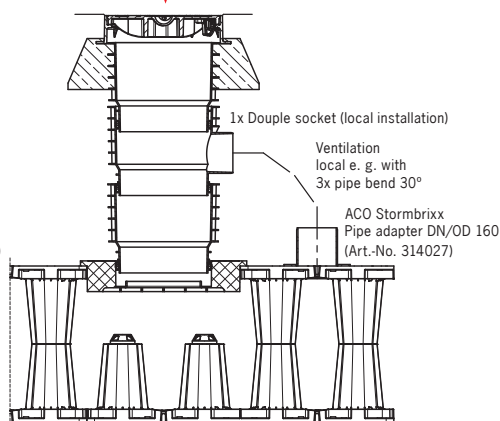

Within the box
via the ACO Stormbrixx upper part
(inner diameter = 339 mm)
in connection with the access plate
(inner diameter = 400 mm)

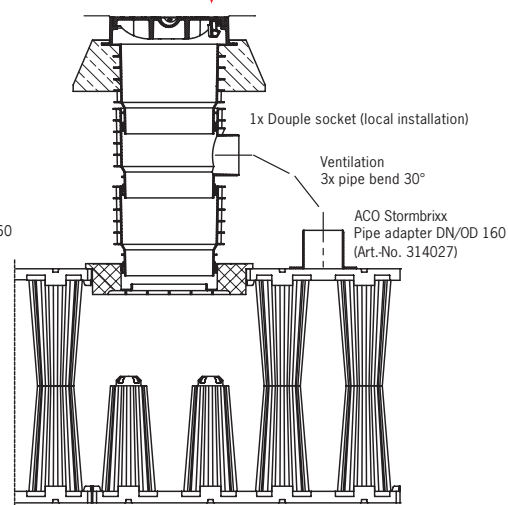

Shaft cover SA 400

The shaft cover has a maintenance free, screw-free and traffic-safe catch made from highly wear-resistant plastic (conforms to DIN EN 124 / DIN EN 1229, is stable at extreme temperatures, repels dirt, is self-locking and vandal-proof). Once the cover has been put in place, it can be locked into place by stepping on it vertically on the area sitting over the frame. A concrete seating surrounding the upper section provides the load transmission for the shaft cover. A concrete seating C12/15 approx. 20 cm wide is created all the way around, as defined by DIN EN 206-1, and raised by 2 cm to the highest drain upper section.

Use the inserted temporary cover/formwork to smooth off the inserted concrete flush. Then remove the temporary cover/formwork, press the frame into the wet cement base to a depth of approx. 2 cm until it is completely seated on the upper shaft section or as required for the final height.

After inserting the frame, it is possible to use a dirt bucket compliant with DIN 4052-B, low profile.

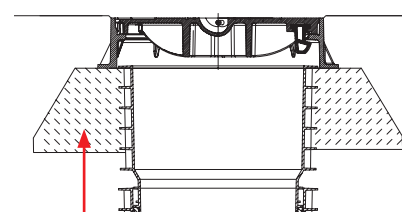

Depth of concrete: 20 cm
Concrete quality: \geq C12/15
When installing, make sure that the recording free for the lid locking cams must remain.

Available with and without air vents



Making the pipe connections

ACO Stormbrixx pipe adapters must be used for the connection of inlets and outlets and ventilation pipes at the side panels of the infiltration system. Sizes from DN/OD 110 to DN/OD 315 are available.

Pipes size DN/OD 400 are connected laterally only via the shaft base or intermediate section of the ACO Stormbrixx HD infiltration system.

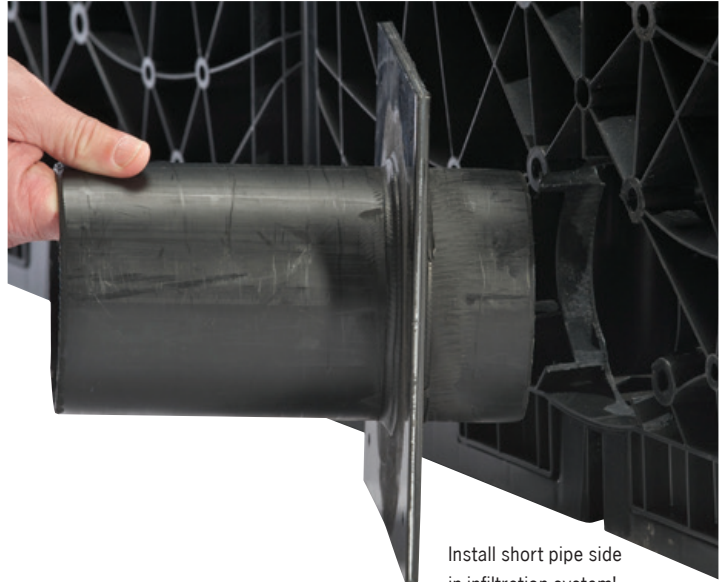

Install short pipe side in infiltration system!

Side openings

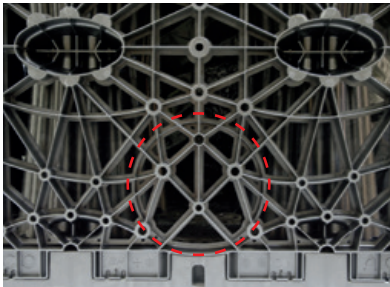

The openings for inlets and outlets must be cut out before installing the side panels

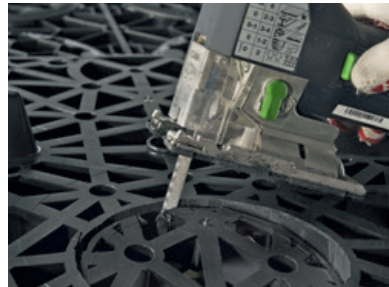

A keyhole saw with extra-long saw blade is required to cut out the pipe connection opening in the side panel

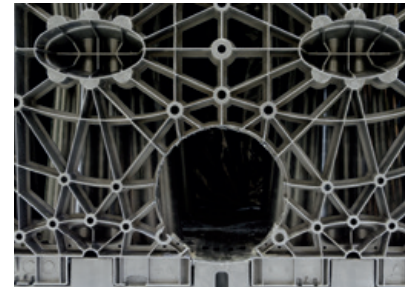

Top openings

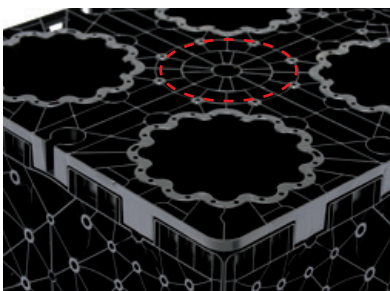

The openings for ventilation and the inspection openings must be cut out of the basic elements before they are installed



A keyhole saw with extra-long saw blade is required to cut out the openings for the pipe penetrations in the side panels and at the top of the basic elements

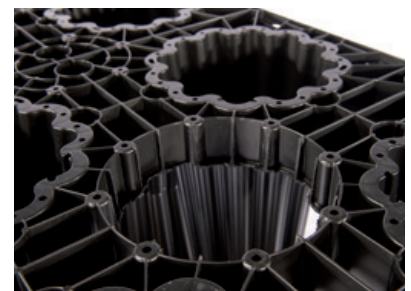



Markings on the side panels indicate the opening sizes for different pipe diameters

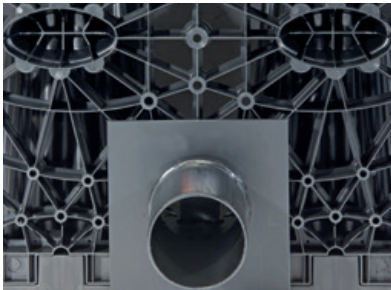

The pipe adapter is mounted in the previously cut out opening in the side panel



The geotextile is cut in and is pushed over the pipe adapter



The pipe adapter is mounted in the previously cut out opening at the top



The geotextile is cut in and is pushed over the pipe adapter

Pit excavation and surrounding the infiltration system

The soil must be load-bearing and sufficiently permeable for infiltration. In case of non-load bearing soil the geological conditions must be investigated and suitable measures taken. The load-bearing substrate must be stone-free, flat and without a gradient.

The bedding consists of the in situ soil or exchanged soil with a minimum load-bearing capacity of $EV2 \geq 45 \text{ MN/m}^2$ and an approx. 5 cm thick blinding layer (chip-

pings/gravel without fines) with grading range 2/8. This blinding layer must be drawn off flat.

The permeability of the soil must be ensured even after compaction. The quality of this bedding is decisive for the further laying and has a significant influence on the load-bearing and settlement behaviour of the hollow block infiltration systems, especially where a multi-layer structure is used or large loads occur (soil/traffic load).

The system must not be installed permanently or temporarily in in-situ groundwater, stratum or perched water. The relevant recommendations of the DWA-A 138 standards must be taken into account for infiltration systems. Accordingly, the distance to the mean highest groundwater level should be at least 1.0 m.

Infiltration – Laying the Filter Fleece

The entire block infiltration system must be surrounded with **filter nonwoven (geotextile robustness class: GRC 3, Weight: 200 g/m², Thickness: 1.9 mm)**. Before laying the basic elements, the nonwoven must be laid out on the blinding layer with sufficient overhang. ACO Stormbrixx is completely surrounded with the filter nonwoven, to prevent the penetration of fine soil fractions. At least 0.50 m overlap must be maintained on all sides of the infiltration system. Ensure that the nonwoven fits tightly on the ACO Stormbrixx system and soil does not penetrate between the components and the nonwoven enclosure.

The filter nonwoven is dimensioned as follows: Length of the nonwoven sheets = infiltration system perimeter + **at least 0.50 m overlap**. The two ends of the geotextile are temporarily and adequately fixed on the trench slopes or edges. After installing the ACO Stormbrixx components the filter nonwoven is detached from the trench slopes/edges and is placed over the infiltration system with overlap at the nonwoven joints. Ensure that the nonwoven fits tightly on the ACO Stormbrixx System and soil does not penetrate between the components and the nonwoven enclosure.



After creating a level surface which is free of stones, even and without gradient the trench is lined with a filter fleece.

Please note!

Take care that the overlaps are always at least 50 cm, that the fleece surface is completely sealed and that it cannot fall open during in-fill.

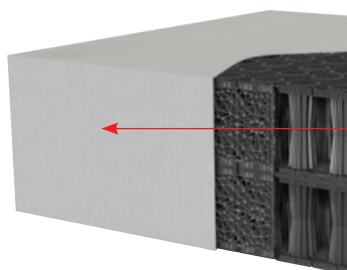

Geotextile, filter fleece, weight: 200 g/m²

Infiltration geotextile

- Geotextile robustness class GRC 3
- Weight: 200 g/m²
- Thickness: 1,9 mm
- Characteristic opening width: 0,08 mm
- Water permeability to EN ISO 11058: 90 l/sm²



Attenuation – Laying the protective fleece and sealing membrane

If the modular ACO Stormbrixx infiltration system is used to retain surface water, the entire system must be surrounded by a **waterproof membrane (2 mm thick)** and welded. The waterproof membrane must be protected against mechanical damage by a **protective nonwoven (weight 400 g/m²) on both sides**.

The pipe adapters and shaft upper parts must be welded with the sealing membrane. The sealing membranes must be welded by examined qualified welders with testable welds in accordance with the DVS guidelines. The tightness of the welds must be verified and appropriate test records must be submitted to the client. The work must be carried out by a specialist company with examined plastic welder.

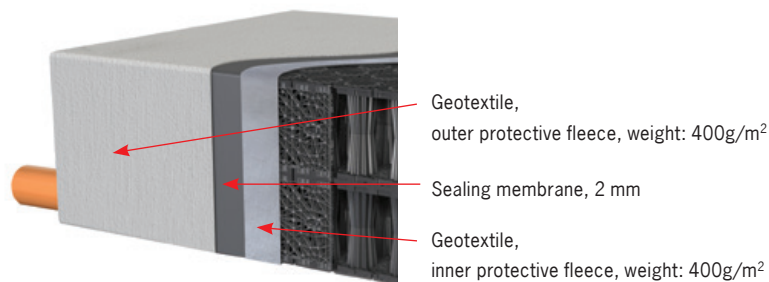

Important!

It must be ensured that the surface of the nonwoven and waterproofing is completely closed and no openings can occur during backfilling!



Covering over – Infilling

Recognised good technical practice, and applicable laws and standards must be respected (such as „Additional technical specifications and guide lines for soil works in road constructions“ (ZTV E-StB), „Directive for standardisation of upper surfaces for road constructions“ (RstO)).

Filling the trench sides

The stone-free infill material (which must meet DIN 18196) must be compactable and able to absorb percolated water. The coefficient of permeability of the infill material must at least match the calculated kf-value.

Side infilling is to be carried out according to DIN EN 1610, in layers no deeper than ≤ 30 cm each time, up to the upper edge of the trench.

Compact the fill material with a light-weight compactor to a Proctor value of approx. 97%. Avoid any direct contact between the compactor and the plastic components. The insertion of the infill material must not create any problematic distortion, damage or inappropriate loading of the trench system. Care must be taken when infilling and compacting that the overlaps of the geotextile are not disturbed and pulled apart, and that the ACO Stormbrixx system is not damaged!

Covering

After completing the infilling around the sides, a compacted covering of 10 cm of stone-free filler material and a 35 cm thick load-bearing layer of e.g. road metal are placed over the infiltration system to create a flat base for the subsequent structure.

Covering the ACO Stormbrixx system must be done in layers, tipping materials from the edge. For this e.g. a light-weight backhoe or wheel loader can be used with a maximum total weight of 15 tonne (4 double wheels). This equipment may only be driven over the site once it is covered by a sufficiently compacted layer with a thickness of ≥ 45 cm, while taking care not to create tracks.

For surfaces which will carry traffic the current road construction regulations apply (RStO). During and after the construction phase care must be taken to ensure that no dirt enters the infiltration system.

Please note!

Compaction using heavy vibrating rollers is not permitted! Driving construction vehicles directly over the ACO Stormbrixx system is not permitted! Driving heavy construction vehicles directly over the ACO Stormbrixx system is only permitted when there is a compacted covering at least 100 cm thick.

The respective maximum permissible impacts that are given for the operating status of the systems ACO Stormbrixx SD and ACO Stormbrixx HD must not be exceeded.

This applies in particular to construction traffic during the construction phase.



Planning instructions and technical regulations

The information in this brochure, our application technology consultancy advice, and any other recommendations are based on a large volume of scientific research and many years of experience. Nevertheless, they are only indicative, and designers and fitters remain responsible themselves for checking the products and the installation instructions in combination with all local circumstances, current technical regulations and the current state of the art of the technology, and we accept no liability.

ACO Stormbrixx is a modular infiltration system made from synthetic materials which, on the one hand provides bulk storage, and on the other hand is used to provide bulk percolation of storm water. The installation is carried out totally below ground level. Providing the correct earth covering is an essential part of this (see Page 42/43). The prerequisites for long-term operation are advance and careful planning, correct installation by professionals and where relevant connection to a functioning watercourse, together with regular maintenance/cleaning. The **standards for concrete** given in the ACO Tiefbau installation details are minimum values. Any special requirements which arise from local conditions (resistance to frost, road salt, chemicals, abrasion etc.) need to be taken into account by designers, applying the correct **choice of exposure class** as defined in DIN EN 206-1 and DIN 1045-2. For the selection and design in particular, but also for the installation of Stormbrixx, the following **technical regulations** apply in their current versions.

DIN 1045-2 „Reinforced and pre-stressed concrete structures – Part 2: Concrete – Specification, performance, production and conformity; Application rules for DIN EN 206-1“

DIN 4124 „Slopes, planking and strutting, breadths of working spaces“

DIN 18196 „Civil Engineering – Soil classification for civil engineering purposes“

DIN EN 206-1 „Concrete – Specification, performance, production and conformity“

DIN EN 1610 „Construction and Testing of Drains and Sewers“

DWA (German Association for Water, Wastewater and Waste) and ATV-DVWK (former name of above) work instructions

■ A 166 Structures for centralised storm water treatment and retention, 1999

DWA and ATV-DVWK fact sheets

■ M 176 Notes and examples for the design and equipment of structures for centralised storm water treatment and retention, 2001

■ M 178 Recommendations for the planning, construction and operation of retention ground filters for additional rainwater handling in mixed and separated systems, 2005

(In addition to the DWA rules listed on page 64)

RAS-Ew „Directives for Road Design – Section: Drainage“

RStO „Directives for the Standardization of Traffic Area Surfaces“

VOB (standard building contract terms) Part C:

ATV (general technical requirements) DIN 18299 „General regulations for construction work of all kinds“

VOB Part C: ATV DIN 18300 „Excavations“

VOB Part C: ATV DIN 18315 to 18318 „Construction of traffic-bearing roads; Surface courses without binder/ ... with hydraulic binder/... made of asphalt/ ... dry-jointed sett and slab pavements and surrounds“

Working paper „„Surface pavements with pavings and slabs by bonded construction“ ((Research Company for Roads and Traffic) FGSV-No. 618/2)

ZTV Asphalt-StB „... for the Construction of Asphalt Pavement Surfaces“

ZTV Beton-StB „... for the Construction of Concrete Pavement Surfaces“

ZTV E-StB „...for Civil Engineering for Road Construction“

ZTV Ew-StB „Additional Technical Terms of Contract and Directives for the Construction of Drainage Systems in Road Construction“

ZTV P-StB „... for the Construction of Dry-jointed Sett and Slab Pavements“ (without binder)

ZTV T-StB „... for the Construction of Base Courses for Road Construction“

The above list of regulations, standards and directives is indicative only for the design and implementation of line drainage in surfaces which bear traffic, and makes no claim to be exhaustive. To provide verification and certainty we recommend a local hydraulic test be organised on your site by ACO Application engineering. For special applications or for solutions which you do not see in this documentation, please contact ACO Application engineering. Our colleagues will be pleased to advise you and assist you in finding the best solution. Please contact them in your country.

Please also refer to the legislation and technical regulations.

Maintenance and inspection

Visual Inspection, maintenance and cleaning

Thanks to the intelligent building block architecture of ACO Stormbrixx, which requires only an external perimeter to the entire system using easy-to-erect side walls, the total volume of the installed infiltration system is accessible for inspection and washing.

Basically, maintenance work needs to be thought about during the planning phase. In detail, this may mean: in addition to the maintenance instructions we always recommend adhering to all the current relevant legal requirements (DWA-A 138 with instructions for the maintenance of infiltration systems)

During and after the construction phase care must be taken to ensure that no sediment enters the inlet pipes, shafts and the infiltration system. During and immediately after the construction phase an increase in the volume of sediment must be expected from the connected surfaces and must be counteracted.

Maintenance frequency

The initial inspection/cleaning of the ACO infiltration system should take place after completion and before handover, so forming part of the commissioning of the installation.

A visual inspection of the shafts and a camera passage through the pipes and the infiltration system is recommended. The results should be recorded in an operating logbook.

To guarantee long-term operability, the recommendations of the current relevant legal requirements must be respected (DWA-A 138, instructions for the maintenance of infiltration systems).

A visual inspection must be carried out at least twice a year, preferably in the spring (high pollen levels) and autumn (falling leaves). If necessary, maintenance/cleaning should be undertaken.

The operator is responsible for ensuring that all maintenance work is carried out by qualified expert staff, who are fully aware of the maintenance and operating instructions.

Relevant accident prevention regulations must be respected.

The results of the inspections carried out can then be used to determine the frequency of maintenance interventions in future.

If unusual weather conditions occur (heavy rainfall or similar), additional inspections and/or maintenance are recommended.

The inspection equipment can be moved freely through the trough-shaped indentations in the base plates of the system



Camera, jetting nozzle

The inspection and cleaning accesses, consisting of shaft bases, intermediate sections and upper parts, provide an easy way for sewer cameras, jetting nozzles and jetting lances to access the ACO Stormbrixx hollow block infiltration system (see page 50–53).

Cleaning

The cleaning of the ACO Stormbrixx infiltration system can if necessary be carried out using sewer cleaning equipment (sewer cleaning technology/high-pressure washing). The maximum water pressure must not exceed 100 bar.

The water can be sucked out through the upper sections and the lower and intermediate shaft sections.

When disposing of the cleaning water/sediment all applicable legal requirements must be observed.

Visual inspection

Visual inspection includes the following points:

- The condition of the infiltration space (side walls, bases, covers, columns)
- Connecting pipes

If there are signs of leakage, the watertightness of the system must be re-established by suitable tests.

Maintenance measures

If faults are detected during the visual inspection (dirt, distortions etc.) these must be corrected immediately.

Operating logbook

The results of the visual inspection and any maintenance and repair measures undertaken must be recorded in an operating logbook. These records then allow decisions to be made about the necessary frequency of future visual inspections and maintenance measures.

The following data and information must be recorded in the operating logbook:

- Completeness of the operating log book
- Date of visual inspection or maintenance work
- Identity of staff involved
- Problems arising (also causes of problems)
- Measures taken

Keeping a logbook has many benefits, e.g. traceability of sources of problems, targeted error analysis and determination of follow-up measures.

Warranty

Please refer to the relevant section in the general terms and conditions of sale of the ACO company in your country.

Vertical access directly through the system



Push camera, cleaning equipment with a rinsing



Self-propelling camera





**Every product from ACO Tiefbau
contributes to the ACO system chain**

- Drainage channels
- Road gullies and yard drains
- Gully tops
- Manhole covers
- Separators
- Backup systems
- Rainwater treatment
- Pumping stations
- Tree grids
- Amphibian conservation

ACO Tiefbau Vertrieb GmbH

PO Box 320
24755 Rendsburg
Germany
Am Ahlmannkai
24782 Büdelsdorf
Germany
Tel. +49 (0) 4331 354-500
Fax +49 (0) 4331 354-358

PO Box 1125
97661 Bad Kissingen
Germany
Neuwirtshauser Strasse 14
97723 Oberthulba
Germany
Tel. +49 (0) 9736 41-50
Fax +49 (0) 9736 41-21

tiefbau@aco.com
www.acostormbrixx.com
www.aco-tiefbau.de